

AirSpade® Vac Operator Manual

Part Number AVU16540



AIRSPADE®
PNEUMATIC SOIL EXCAVATION

TABLE OF CONTENTS

PRECAUTIONS.....	3
GENERAL INFORMATION.....	4 - 5
PRODUCT SPECIFICATIONS	6
OPERATION INSTRUCTIONS.....	7 - 8
MAINTENANCE	9
TROUBLESHOOTING.....	10
USING WITH AN AIRSPADE.....	11
WARRANTY INFORMATION	12



Always wear eye and ear protection when operating air tools and related equipment.

PRECAUTIONS

Do not operate AirSpade Vac before thoroughly reading these instructions.

WARNING

- Do not make any modifications to the AirSpade Vac.
- Do not tie, tape, or otherwise lock the air valve of the AirSpade Vac into its operating position.
- Do not point or aim the vacuum wand at any person during operation.
- Do not put hands or clothing in front of or into the vacuum wand.
- Do not expose bare skin of self or others to the vacuum air stream.
- Always use the exhaust bag to prevent material exiting the tank through the exhaust stream.

CAUTION

- Always wear Personal Protective Equipment (PPE) when working in excavation zones. Safety eyeglasses meeting ANSI Z87.1 1989, head protection, hearing protection, work clothes, work boots, and puncture resistant gloves are recommended.
- Hearing protection providing a minimum NRR of 20 dBA should be used if the AirSpade Vac is operated for prolonged periods according to standard OSHA Regulations 29 CFR 1926.52.
- Personnel within close proximity to the point being excavated should use proper PPE.
- Prior to operation, ensure that personnel near the area being excavated are aware that the AirSpade Vac will be used.
- Follow the manufacturers' manuals for operation and maintenance of the air compressor and other tools.
- Care must be exercised to balance the AirSpade Vac over its wheels when moving from location to location.
- Exercise caution when moving; dumping; or loading/unloading the AirSpade Vac from a transport vehicle.
- Inspect tank for damage, including dents or cracks. Damaged tanks may collapse under high vacuum.
- Wear approved insulated footwear and gloves if working near underground electric utility lines.

AirSpade Vac is a powerful, high-capacity, portable compressed air powered vacuum system designed for safe excavation of all types of buried objects including pipes, cables, and tree roots. Utilizing patented supersonic nozzle technology to produce superior air flow and vacuum lift, the AirSpade Vac features:

- Durable, lightweight 82-gallon aluminum tank with over ¼ cubic yard of spoil capacity (enough to dig two potholes 12" in diameter by 5' deep).
- Removable engine for easy setup, transportation, and storage.
- Exhaust silencer for quiet operation and filtering of fine dust.
- Rear handles for superior maneuverability.
- Storage pockets and slots for tools and equipment.
- Wide tires with tread pattern for rugged and off-road traction.
- Wide opening dump-door with quick release latches for easy to empty operation.

DESCRIPTION OF OPERATION

The AirSpade Vac consists of a tank assembly and removable vacuum engine assembly. The engine rests on top of the tank lid secured by a bungee but is removable for transport and storage (**Figure 1**).



FIGURE 1

The engine creates a vacuum in the tank achieved by a supersonic jet of air passed through a multistage venturi system. Unlike single-stage venturis, which are designed to work optimally for a single material type, this multistage system allows for optimal performance for all types of material (e.g. dry/lightweight loam to wet/heavy mud).

The multistage system consists of a nozzle and three venturi chambers. The nozzle is supplied compressed air and generates a supersonic airstream moving at twice the speed of sound, Mach 2. This airstream passes through the three venturi chambers. Depending on the material type, a chamber will be open or closed, and this feature is what gives the AirSpade Vac do-it-all capabilities (**Figure 2**).

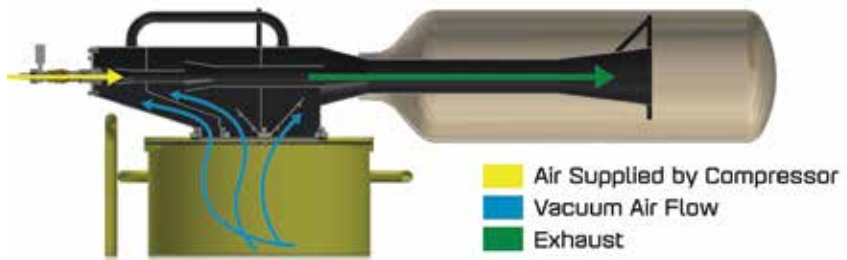

FIGURE 2

With the flexible vacuum hose connected to the tank, air and material are transported from the open end of the vacuum wand to the tank inlet. Hose clamps allow for easy assembly and disassembly in the field for cleaning and transport of the hose and wand. Air and material entering the tank through the inlet tube are directed toward the bottom of the tank. Material accumulates on the bottom of the tank and then gradually fills upward.

Vacuum exits the tank through the venturi chambers and then exits out of the exhaust to atmosphere. A washable polyester exhaust bag is included to filter out any fine dust or debris. The exhaust bag is held on the exhaust housing by a hose clamp.

The tank lid is removable for access to the tank interior and is held in place with quick release latches. Handles are provided on the AirSpade Vac for its lifting but are not intended to support the entire weight of the tank if full.

The AirSpade Vac has two wheels and rear handles for manual transportation. A wide dump door with quick release latches is located at the front bottom of the tank so that material can be easily removed.

Minimum Air Supply Requirements

Pressure	90 psi
Flow	165 cfm

Performance

Max Vacuum Flow	750 cfm
Max Vacuum Lift	262 in H ₂ O
Noise @ 5ft	99 dBA

Recommended Compressor Size
185 cfm @100psi

Dimensions

Max Tank Volume	82 gal
Weight	199 lb
Max Load	750 lb
Vacuum Hose	4" ID x 15'

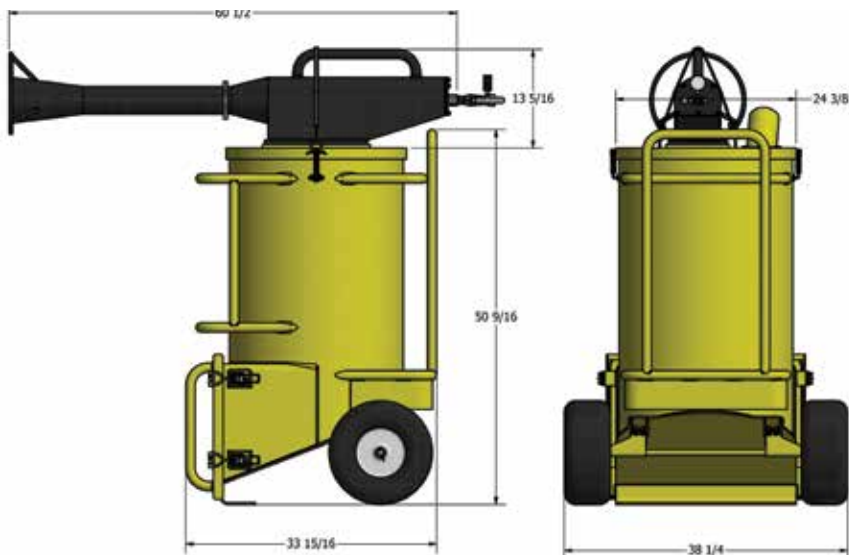

PRIOR TO OPERATION

Prepare AirSpade Vac

- Locate the AirSpade Vac unit on level ground and chock its wheels to prevent accidental movement.
- Place engine on top of tank lid and secure using bungee. Cover can be rotated in any direction.
- Ensure engine's exhaust is pointing away from personnel in the area.
- Make sure the air supply shut-off valve on the AirSpade Vac is closed. As such, the valve handle position should be at a 90 degree angle to the incoming air line.
- Ensure exhaust bag is installed and secure. **Always use the exhaust bag to prevent material exiting the tank through the exhaust.**
- Connect vacuum hose to hose inlet. Tighten all connections.
- Check to ensure that the open end of the vacuum wand is free of all obstructions.
- Ensure that the tank lid and tank door are both latched properly and securely.
- Inspect AirSpade Vac for loose or damaged parts and tighten or repair as necessary.

Prepare Compressor

- Make sure all air discharge valves at the air compressor are closed.
- Connect air supply hose of the proper size (ID) and length from the air compressor to the AirSpade Vac. Refer to Table 1 for air supply hose sizing and Table 2 for maximum length recommended for proper operation.
- Make sure air supply hose couplings are connected properly, with safety pins in place.
- Inspect the air line for leakage, kinks, abrasion, corrosion, or any other signs of wear or damage. Worn or damaged hose assemblies should be replaced immediately.

TURN ON UNIT

- Start the air compressor according to manufacturer's instructions.
- The air compressor should build pressure until 100–120 psig is shown on the air compressor pressure gauge.
- Slowly open the air discharge valves on the air compressor.
- The AirSpade Vac inlet pressure gauge should read 100–120 psig.
- Grab hold of the vacuum hose and wand, then slowly open the air supply shut-off valve on the AirSpade Vac.
- The AirSpade Vac inlet pressure gauge should now show 85–95 psig for normal operation.
- AirSpade Vac is now ready for use.

IN USE DESCRIPTION

During normal operation, AirSpade Vac will pick up approximately 1 to 2 cubic feet per minute of materials such as dirt, sand, gravel, rocks, or water. For best results, material to be vacuumed is first loosened and/or broken into small pieces. When the vacuum wand is brought close to the material, the vacuum air stream sucks the material into the vacuum.

Airflow is key to successful vacuuming. It is best to not jam the vacuum wand into the ground, as the airflow would essentially be zero. It is recommended to lightly dance the wand over the material and carve out the hole with the wand. A shovel or AirSpade (see page 10) can be used simultaneously while vacuuming to expedite the process.

With a 4" diameter, the vacuum hose has no problems with dirt or small rocks clogging in the hose. For material such as clay, which tends to clump together; break the material apart with the wand and try to keep the vacuum hose straight, as the material will clog on the bends.

.....

EMPTYING

- When full of material, one person should not move the AirSpade Vac alone.
- The AirSpade Vac tank will require emptying after about ¼ cubic yard of material has been vacuumed and removed from the excavation. Note that soil typically swells during

excavation. For example, 1.0 cubic feet of dry compacted earth expands to 1.3 cubic feet when excavated.

- Unlock each of the four dump door latches by pulling the handle and releasing the hook. Remove door.
 - The inside bottom of the AirSpade Vac is angled to facilitate emptying.
 - After the material has cleared the dump door opening, brush off the inside surface of the dump door and make sure the door gasket is clean and free of debris.
 - Return the door to its original position and lock the latches.
 - **IMPORTANT** – be sure that the door fits tightly against the door flange compressing the gasket. Air leakage at the door seal can adversely affect the suction and vacuum flow through the vacuum wand. The latches can be adjusted to create a tighter seal between the door and tank.
-

SHUT DOWN

- Turn off the AirSpade Vac air inlet valve.
- Turn off the air compressor discharge valve.
- Open the AirSpade Vac inlet valve to purge the AirSpade Vac and compressed air line. The pressure gauge should read "zero." Close the inlet valve.
- Shut down the air compressor.
- It is now safe to disconnect the air supply hose.

MAINTENANCE

- Check that all gaskets and sealing surfaces are airtight (**Figure 3**).
- The valves need regular cleaning, as dust and dirt may build up over time. The valves need to be clean, so they can move freely and make a proper seal. Check that the hinges and mating surfaces are clear of dirt. Do not use cleaning agents, water is all that is needed (**Figure 4**).
- Wash engine interior with a low-pressure hose after use. A soft brush may be used to scrub. Access points are the air inlet, bottom of engine, and exhaust outlet. Remove air inlet cover to access venturis.
- Wash tank interior and exterior after use.
- Inspect the tank for damaged paint and touch-up as needed.
- Check the tire pressure regularly. Inflate to 30 psi max.
- Remove the exhaust bag and shake any dirt out. Wash the exhaust bag if needed.

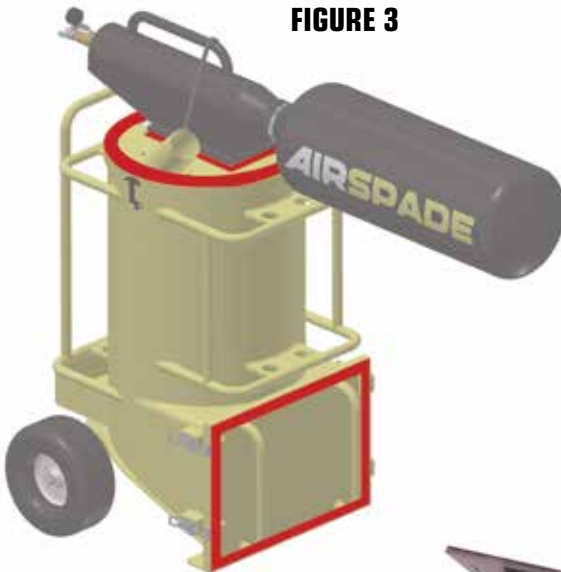

FIGURE 3



FIGURE 4

TROUBLESHOOTING

There are only a few reasons that the AirSpade Vac would not perform correctly. The most common causes of poor performance are an insufficient air supply, leaks at gasket surfaces, or malfunctioning valves.

Is your AirSpade Vac getting the proper air supply?

The AirSpade Vac requires [at the inlet] 165cfm @80-100 psi to operate properly. Check that the inlet pressure gauge confirms this when the AirSpade Vac is operating. If the pressure is correct, the flow (cfm) could be insufficient. This may be due to:

- Leaks in the hose connections
- Undersized compressed air supply line (needs ¾" or larger)
- Compressed air supply line is too long (see page 6-7)
- Undersized air compressor (185 cfm tow behind is recommended).

Are the AirSpade Vac gaskets making proper seals?

The gaskets must make a proper seal to prevent any vacuum leaks.

See Figure 3 on previous page and confirm gaskets aren't deteriorated or contain tears.

Is the vacuum hose making a proper seal with the tank inlet?

For the same reasons as the gaskets, the vacuum hose must make a tight seal with both the tank inlet and the vacuum wand. Check that there are no tears in the vacuum hose.

Are the valves under the engine moving freely?

The valves open and close on their own during normal operation. A pressure differential between the engine and tank is what causes this action. If the valves can't move freely, then the AirSpade Vac will not perform correctly. Check that there is no dirt or contamination at the valve hinges and sealing surfaces. Clean the valve surfaces on a regular basis, as dirt can build up over time.

SOIL EXCAVATION & REMOVAL USING AIRSPADE VAC WITH AIRSPADE

The following standard work practices and operating cautions should be followed to allow safe and best use of the AirSpade Vac in conjunction with the AirSpade.

- In general, the highest rate of soil excavation is achieved by first loosening the soil prior to vacuuming.
- Loosening the soil is best achieved by holding the AirSpade nozzle perpendicular to the ground. This is done by holding the tool in a vertical position, or through use of a 45° adapter.
- Ideally, the tip of the AirSpade should be held approximately 2 inches above the surface of the soil to be excavated and moved horizontally at a rate of about of one foot per second.
- Except in very hard and compacted clays, dwelling on the same spot tends to reduce the rate at which material is excavated and can increase the amount of material blown away from the excavation site.
- After about a 2-inch layer of soil has been loosened, use the AirSpade Vac to remove the loose material from the excavation.
- This process is repeated until the excavation reaches the desired depth.
- For maximum excavation speed, the AirSpade Vac and AirSpade can be used simultaneously if sufficient air flow (scfm) is available from the air compressor.

AIRSPADE PRECAUTIONS

- When using the AirSpade, check that the trigger is not inadvertently depressed and that the tip is pointed away from all personnel.
- When boring a narrow hole in the soil, the tendency to expose the operator to material blown back directly out of the hole is increased. The dirt shield on the AirSpade should be positioned close to the working surface to deflect and confine any excavated material that may become airborne.
- Standard work clothes, safety eyeglasses or face shield meeting ANSI Z87.1 1989, work boots, and puncture resistant gloves offer sufficient protection from any soil debris or small rocks that may be dislodged by the air stream.
- Hearing protection providing a minimum NRR of 20 dB should be used if the AirSpade Vac or the AirSpade is operated for prolonged periods according to standard OSHA Regulations 29 CFR 1926.52.
- Personnel within an area of several feet from the point being excavated should use personnel protection equipment.
- Surfaces that could be chipped or otherwise damaged by small soil or rock particles dislodged by the air stream should be adequately protected, such as by a drop cloth, screen, or canvas barrier.

LIMITED WARRANTY

The AirSpade Vac is guaranteed against defects in material and workmanship for a period of 6 months from the date of purchase. Any components of AirSpade Vac found to be defective within the said warranty period are to be returned to Guardair Corporation, 47 Veterans Dr, Chicopee, MA 01022. Transportation charges on parts and units submitted for replacement under this warranty must be borne by the purchaser.

Guardair Corporation's warranty shall not be effective if the AirSpade Vac has been the subject of misuse, negligence or accident, or if they are configured or used in any manner inconsistent with the directions set forth in this operator's manual.

The purchaser's recovery for damages resulting from any and all causes whatsoever, including, but not limited to, breach of contract, breach of warranty, negligence or strict product liability will be limited to the replacement of the components of the AirSpade Vac with respect to which losses or damages are claimed, provided that Guardair Corporation has been notified of any alleged defect within the warranty period.

IN NO EVENT SHALL GUARDAIR CORPORATION BE LIABLE TO THE PURCHASER OR ANY USER OF THE AIRSPADE VAC, OR TO ANY OTHER PERSON OR ENTITY, FOR INDIRECT, INCIDENTAL, OR CONSEQUENTIAL DAMAGES, INCLUDING THE COST OF PROVIDING SUBSTITUTE EQUIPMENT DURING PERIODS OF MALFUNCTION OR NON-USE AND DAMAGES FOR DELAY.

THE WARRANTIES AND REMEDIES SET FORTH ABOVE ARE THE SOLE AND EXCLUSIVE WARRANTIES AND REMEDIES AVAILABLE. GUARDAIR CORPORATION SPECIFICALLY DISCLAIMS ALL IMPLIED WARRANTIES OF MERCHANTABILITY AND FITNESS FOR A PARTICULAR PURPOSE AND ALL OTHER WARRANTIES, WHETHER EXPRESS, IMPLIED OR STATUTORY.

AIRSPADE®

PNEUMATIC SOIL EXCAVATION

47 Veterans Drive • Chicopee, MA 01022-1062

Toll-Free: 800-482-7324 | Local: 413-594-4400 | Fax: 413-594-4884

airspade.com | info@airspade.com

AV5000-3